

Section D

ACCELERATOR

Index No.	Part No.	Description
1.	47-021476-001	Ball Accelerator Box
2.	11-051019-001	Hex Hd. Cap Screw (10 mm x 25 mm)
3.	11-052018-001	Flat Washer (10.5 mm x 21 mm x 2 mm)
4.	47-021249-004	Ball Cushion Stop
5.	11-051745-001	Locknut (10 mm)
6.	47-021057-003	Ball Door Protector Ring
7.	47-021481-003	Fiber Plate (small)
8.	47-021619-002	Protector Wedge (right-hand)
9.	47-021620-002	Protector Wedge (left-hand)
10.	11-051543-001	Socket Hd. Cap Screw (10 mm x 20 mm)
11.	11-051771-001	Lockwasher (10 mm)
12.	11-051551-001	Socket Hd. Cap Screw (10 mm x 45 mm)
13.	47-021618-002	Protector Wedge (lower)
14.	11-051512-001	Socket Hd. Cap Screw (10 mm x 35 mm)
15.	11-052454-001	Flat Hd. Machine Screw (6 mm x 16 mm)
16.	11-051743-001	Locknut (6 mm)
17.	47-021480-003	Fiber Plate (large)
18.	47-021478-003	Retaining Plate
19.	47-023950-002	Ladder (short pit)
20.	47-023593-003	Guard Plate
21.	11-051744-001	Locknut (8 mm)
22.	11-051010-001	Hex Hd. Cap Screw (8 mm x 20 mm)
23.	47-031479-004	Retaining Plate Bracket
24.	11-052031-001	Flat Washer (9 mm x 40 mm x 2.5 mm)
25.	11-052017-001	Washer (8.4 mm)

Accelerator Box Assembly

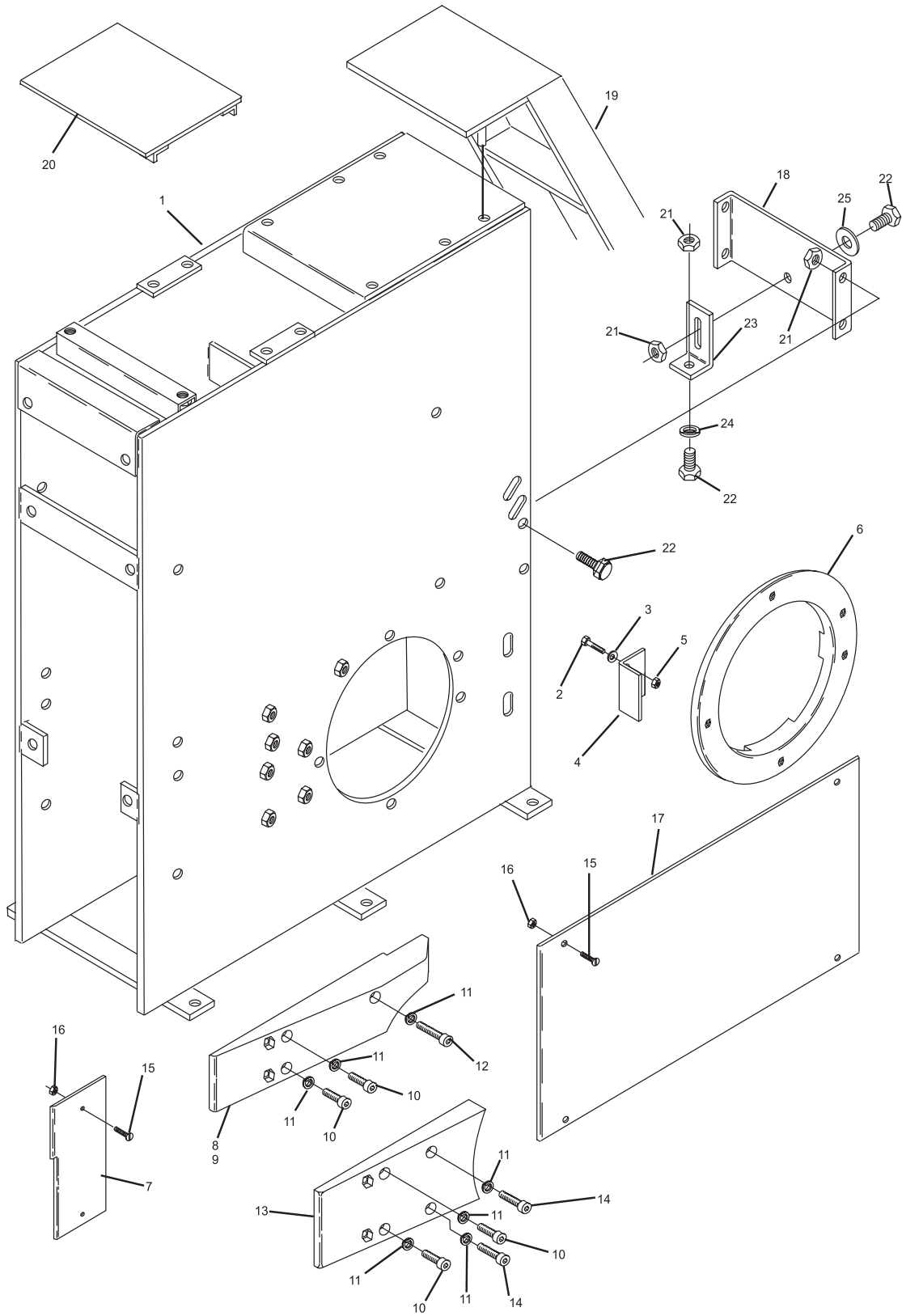

Accelerator Box Assembly

Index No.	Part No.	Description
1.	47-035305-009	Ball Accelerator Box - Complete
2.	47-035240-001	Ball Door Protector Plate (left-hand)
3.	47-035241-001	Ball Door Protector Plate (right-hand) (shown)
4.	11-055800-000	EJOT Plastic Fastener (Nut Plate)
5.	11-054460-000	EJOT Plastic Fastener Screw (25 mm x 60 mm)
6.	11-052008-001	Washer (6 mm)
7.	11-054461-000	Screw (50 mm x 60 mm)
8.	47-035239-004	Axle Wedge
9.	47-035220-003	Accelerator Mount Bracket with Pin - front
10.	11-051019-001	Hex Hd. Cap Screw (10 mm x 25 mm)
11.	11-051745-001	Locknut (10 mm)
12.	11-052018-001	Washer (11 mm x 2 mm x 20 mm)
13.	47-035219-003	Ball Rod Assembly Mount with Pin - rear
14.	11-052020-001	Washer (5 mm)
15.	11-051742-001	Locknut (5 mm)
16.	11-052933-001	Countersunk Screw (5 mm x 12 mm)
17.	47-021249-004	Stop Bracket

GS-X Accelerator Box Assembly

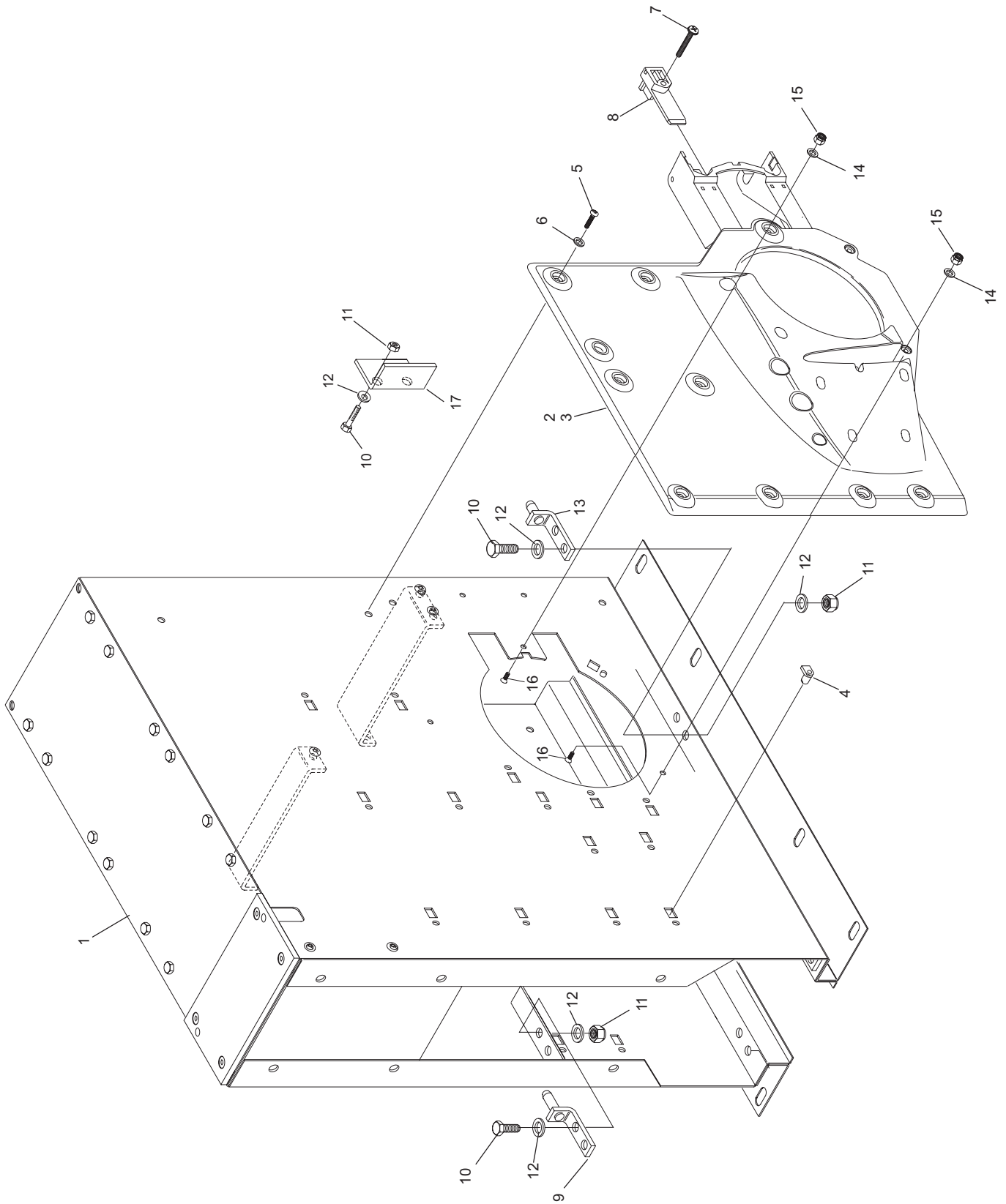

GS-X Accelerator Box Assembly

Index No.	Part No.	Description
1.	47-031455-001	Ball Accelerator Frame
2.	47-031248-004	Tension Spring
3.	47-031440-003	Tension Bar
4.	11-051703-001	Hex Nut (10 mm)
5.	11-053501-000	Key (5 mm x 5 mm x 25 mm)
6.	47-031454-002	Pivoting Lever
7.	47-031456-004	Axle
8.	11-052926-001	Flat Hd. Cap Screw (10 mm x 20 mm)
9.	11-051045-001	Hex HD. Cap Screw (10 mm x 30 mm)
10.	11-051745-001	Locknut (10 mm)
11.	10-635127-000	Flat Belt
12.	***47-035232-002	Driving Drum Complete (front)
13.	47-035064-099	Driving Drum Complete (rear)
14.	11-051015-001	Hex Hd. Cap Screw (8 mm x 25 mm)
15.	11-052028-001	Flat Washer (10.5 mm x 25 mm x 2 mm)
16.	11-052017-001	Flat Washer (8.4 mm x 15 mm x 1.6 mm)
17.	11-051744-001	Locknut (8 mm)
18.	11-052017-001	Washer (8.4 mm)
19.	47-862787-000	Plastic Tube (package of 4)
20.	11-052609-001	Carriage Bolt (8 mm x 100 mm)
21.	11-680925-000	Strain Relief
22.	68-100192-000	Cable Assembly
	*47-142614-000	Cable Assembly (GS Consolidated Electronics)
23.	47-031309-001	Ball Rod
24.	53-861063-000	Transition Track (GS Accelerators to Return Track)
25.	11-051045-001	Hex Hd. Cap Screw (10 mm x 30 mm)
26.	11-051771-001	Lockwasher (10 mm)
27.	11-052018-001	Flat Washer (10.5 mm x 21 mm x 2 mm)
28.	47-031261-004	Spacer
29.	11-053577-000	Rubber Bumper
30.	11-051028-001	Hex Hd. Cap Screw (6 mm x 25 mm)
31.	11-051702-001	Hex Nut (6 mm)
32.	47-031603-003	Motor Mounting Bracket
33.	11-051769-001	Lockwasher (6 mm)
34.	11-051704-001	Hex Nut (8 mm)
35.	47-031604-004	Shaft
36.	11-051805-001	Split Pin (2.5 mm x 20 mm)
37.	47-031307-004	Angle Bracket
38.	11-051743-001	Locknut (6 mm)
39.	99-010123-004	Bushing
40.	47-031453-004	Spring Bracket
41.	99-020163-004	Spring
42.	**47-033867-004	Motor Drive Pulley
43.	11-053904-000	V-Belt (10 mm x 6 mm x 950 mm, 50Cy, export only)
	11-053907-000	V-Belt (10 mm x 6 mm x 925 mm) 60Cy - domestic only)
44.	11-052804-001	Set Screw (5 mm x 8 mm)
45.	11-051018-001	Hex Hd. Cap Screw (6 mm x 20 mm)
46.	11-052048-001	Flat Washer (6.4 mm x 16 mm x 1.6 mm)
47.	99-040113-002	Ball Accelerator Motor (1/2 H.P., 230VAC/380VAC)
	99-040295-004	Ball Accelerator Motor (1/2 H.P., 208VAC)
48.	47-032500-004	Ball Stop (for welded configuration)
49.	47-032125-003	Guard Bracket
50.	47-032126-003	Ball Stop
51.	47-033504-004	Flat Belt Guard Complete
52.	11-052610-001	Carriage Belt (6 mm x 20 mm)
53.	11-051770-001	Lockwasher (8 mm)
54.	47-022519-000	Ball Wipe w/Sleeve
	47-022519-002	Sleeve only

* Not Illustrated

** Replaces 47-031306-004 Motor Drive Pulley

*** Replaces 47-035063-009 Rear Drive Drum

Ball Accelerator

Index No.	Part No.	Description
1.	47-035236-003	Tension Rod
2.	47-035226-002	Motor Support Bracket
3.	11-051071-000	Hex Head Cap Screw (10 mm x 60 mm)
4.	11-052050-001	Washer (10.5 mm x 30 mm x 2.5 mm)
5.	11-051745-001	Locknut (10 mm)
6.	11-052019-001	Washer (8.4 mm x 24 mm x 2 mm)
7.	11-051704-001	Nut (8 mm)
8.	47-035253-003	Terminal Box
9.	47-862787-000	Protective Tube - package of 4
10.	99-030363-004	Accelerator Motor/Rear Drive Drum Assembly w/Cable - 208/230/380 VAC
11.	47-031248-004	Tension Spring
12.	11-052018-001	Washer (10.5 mm x 20 mm x 2 mm)
13.	11-051020-001	Hex Head Screw (10 mm x 35 mm)
14.	47-031454-002	Pivot Lever
15.	47-035232-002	Front Drive Drum - Complete
16.	10-635127-000	Flat Belt
17.	47-035230-004	Axle
18.	53-861063-000	Transition Track (GS Accelerators to Return Track)

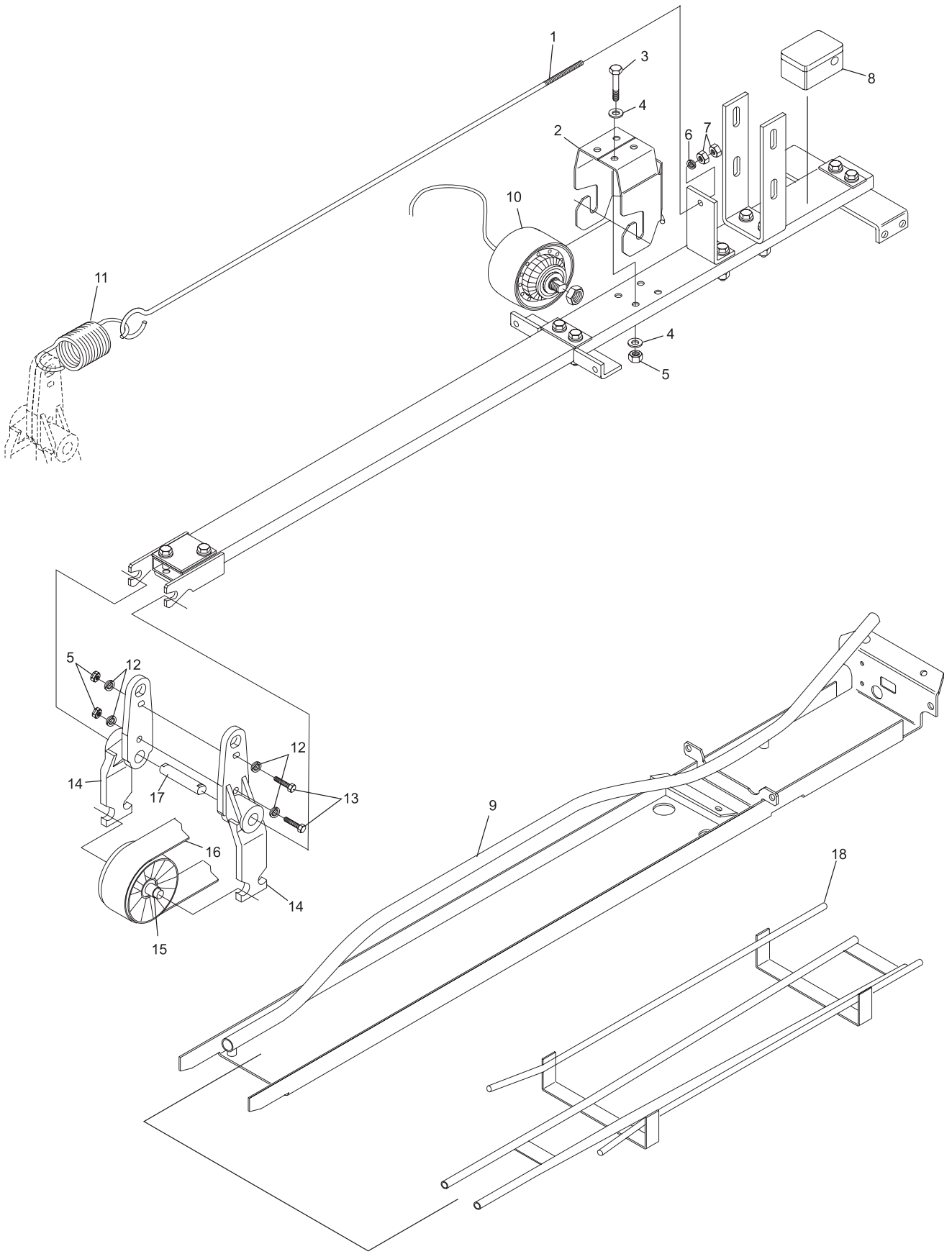

GS-X Ball Accelerator

Index No.	Part No.	Description
1.	*47-031054-002	Ball Door
2.	11-051018-001	Hex Hd. Cap Screw (6 mm x 16 mm)
3.	11-051743-001	Locknut (6 mm)
4.	11-051793-001	Split Pin (2.5 mm x 20 mm)
5.	11-051067-001	Hex Hd. Cap Screw (8 mm x 35 mm)
6.	11-430046-000	Bearing
7.	11-051060-001	Hex Hd. Cap Screw (6 mm x 70 mm)
8.	11-051061-001	Hex Hd. Cap Screw (8 mm x 75 mm)
9.	47-031090-004	Support Brace
10.	*47-031058-001	Arm - Pre GS-X
	*47-031058-991	Arm - GS-X
11.	11-051008-001	Hex Hd. Cap Screw (6 mm x 10 mm)
12.	11-051744-001	Locknut (8 mm)
13.	47-031822-004	Lever
14.	47-031056-003	Button (for left-hand machine Ball Door)
15.	47-031055-003	Button (for right-hand machine Ball Door)
16.	47-034767-004	Spring
17.	47-031091-004	Shaft
18.	11-053478-001	Starlock (8 mm)
19.	47-031302-004	Ball Door Shaft (Pre GS-X Pinsetters)
	47-034843-004	Shaft - Threaded End
20.	11-053477-001	Starlock (7 mm)
21.	11-053616-001	Stop Collar (15 mm x 25 mm x 12 mm)
22.	11-052807-001	Set Screw (6 mm x 8 mm)
23.	47-031797-002	Locking Bolt
24.	47-031800-004	Pivot Link
25.	11-053480-001	Starlock (10 mm)
26.	99-060133-004	Plunger Only
27.	11-051021-001	Hex Hd. Cap Screw (10 mm x 35 mm)
28.	11-052028-001	Flat Washer (10.5 mm x 25 mm x 2 mm)
29.	11-051745-001	Locknut (10 mm)
30.	47-031796-002	Holder
31.	11-051742-001	Locknut (5 mm)
32.	11-680116-000	Connector - Male
33.	**99-060219-004	Solenoid Assembly (red box) Complete
34.	11-051068-001	Hex Hd. Cap Screw (5 mm x 65 mm)
35.	11-052039-001	Flat Washer (5.3 mm x 15 mm x 1.6 mm)
36.	47-031801-004	Connecting Link
37.	11-051791-001	Split Pin (1.6 mm x 10 mm)
38.	47-031799-004	Spring
39.	47-031798-004	Connecting Stud
40.	47-031802-004	Lever
41.	47-033558-009	Locking Mechanism Complete (right-hand)
42.	47-033557-009	Locking Mechanism (left-hand)
43.	**47-243030-004	Solenoid Assembly Complete (silver box)
44.	47-033556-009	Ball Door with Arm Complete (right-hand)
45.	47-033555-009	Ball Door with Arm Complete (left-hand)
46.	47-030276-004	Ball Door Arm Tension Spring
47.	11-054301-001	Hitch Pin (3 mm x 62 mm)
48.	11-680302-000	Terminal - Male
49.	11-680301-000	Terminal - Female
50.	11-680216-000	Connector - Female
51.	11-055253-001	Special Lockwasher (6 mm)
52.	11-053157-001	Jam Nut (14 mm)
53.	47-035238-004	Ball Door Shaft (GS-X Pinsetters)

N.A.=No Longer Available

** Index Nos. 1 and 10 are inverted for use in both left-hand and right-hand machines.*

*** Does not include Plunger, 99-060133-004*

Ball Door/Lock Assembly

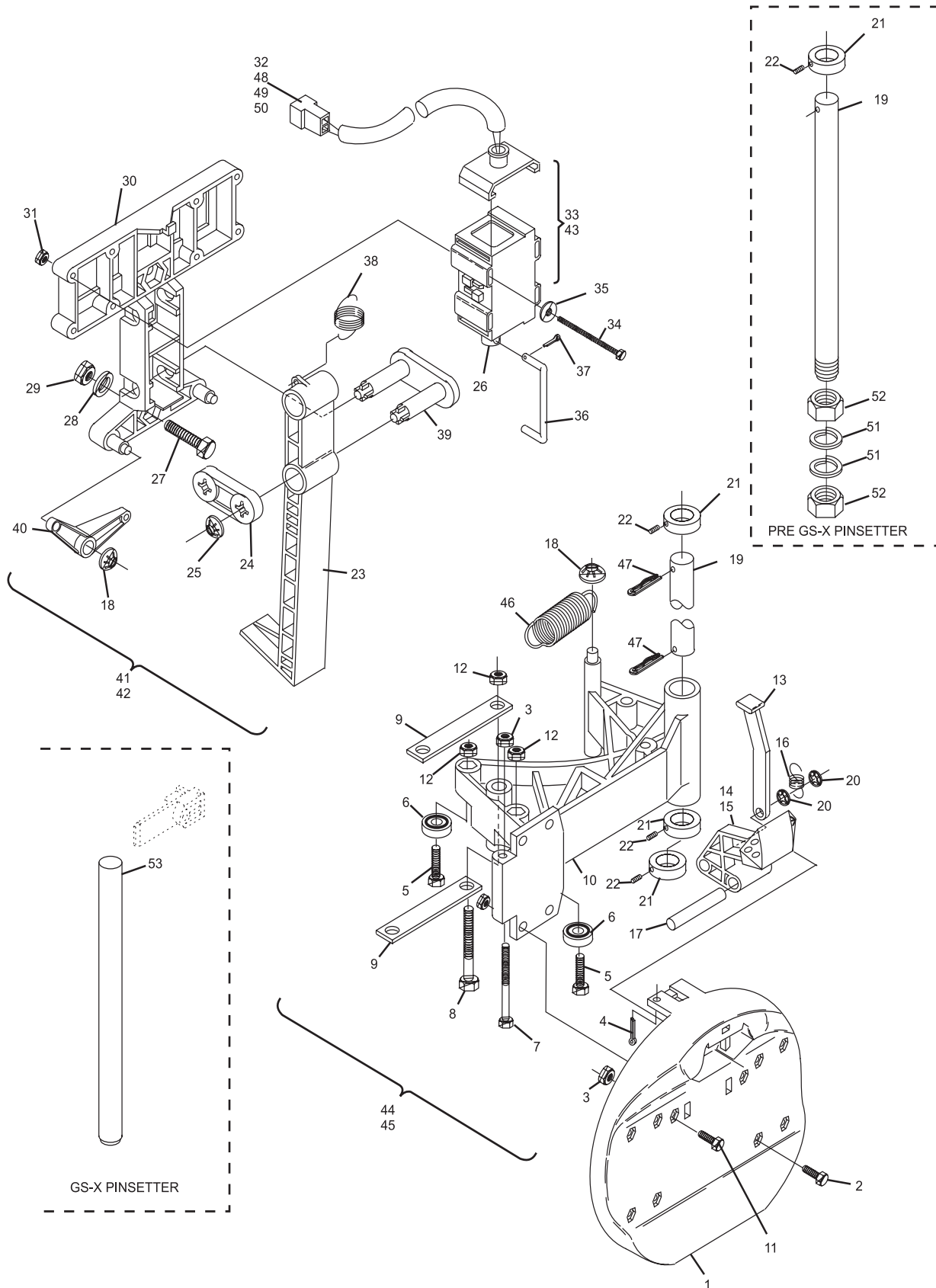

Ball Door/Lock Assembly